

OSCO[®] inc.

RUNNERLESS MOLDING SYSTEMS

Valve Gate and Temperature Controllers

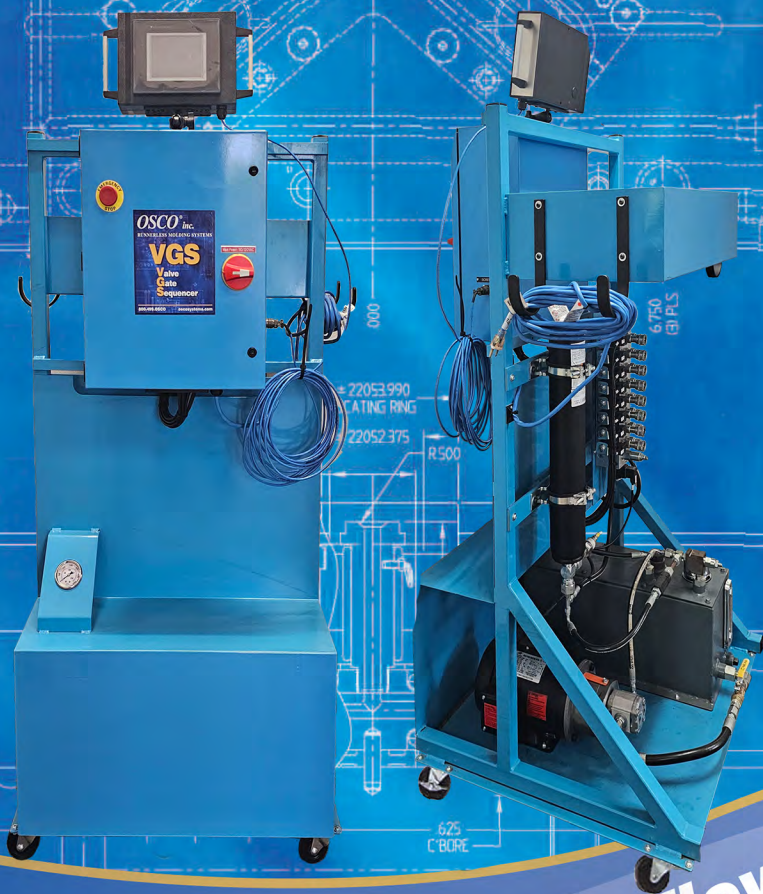

Where Innovation Flows



Proudly Made in the USA

Valve Gate and Temperature Controllers

INDEX

Valve Gate and Temperature Controllers

	Page
☆ Features and Benefits	1
☆ VGS (Valve Gate Sequencer) <ul style="list-style-type: none">• Hydraulic or Pneumatic• 2 - 24 Zones	
☆ Mini - VGS <ul style="list-style-type: none">• Pneumatic• 4 - 8 Zones	
☆ Temperature Controllers <ul style="list-style-type: none">• 1 - 48 Zones• UATC-20 or S20-DC3 Modules• Component Parts• Visions 3000	

HYDRAULIC SEQUENTIAL CONTROLLER

How it works:

- Each controller is furnished with a contact receptacle plug. Connect plug to either an injection forward signal or to a mold parting-line limit switch.
- Once the cycle start signal is given to the controller, the upper delay timers will open the gates after the set amount of time delay expires.
- Lower open timers will keep gates open for the set amount of timed input.
- When the time expires, the gates will close.

Safety Feature:

Anytime mold opens and timers are in "auto" position, Gates will close for operator safety.

Features:

Completely self-contained hydraulic system (pump, motor, manifold, solenoids, valves, filter) with single set-point timers housed in a rugged, compact portable cart. The cart is equipped with hangers for holding hose assemblies.

240 Volts, 3 Phase

How to order:

- ① Specify: Computer part number
- ② Confirm: Number of zones
- ③ Confirm: Voltage

COMPUTER #	# of Zones	# of Timers	Hydraulic Hose Assemblies
EAHSC02	2	4	4 - Hose Assy with fittings - 20' Lg.
EAHSC04	4	8	8 - Hose Assy with fittings - 20' Lg.
EAHSC06	6	12	12 - Hose Assy with fittings - 20' Lg.
EAHSC08	8	16	16 - Hose Assy with fittings - 20' Lg.
EAHSC12	12	24	24 - Hose Assy with fittings - 20' Lg.

VGS

(Valve Gate Sequencer)

Available in Air or Hydraulic



Touch Screen Controller

- Mold storage
- Manual operation
- Test mode
- Troubleshooting
- Color Screen
- Optional linear position switching
- Optional cavity pressure switching
- Portable on 25 foot cord



Mobile Valve Gate Sequencer

- 120, 230, or 460 VAC available.
(120 VAC for up to 10 Zones max)
- Compact – small foot print
- 4, 6, 8, 12, or 16 zones available
- Super quiet
- No water cooling needed
- Over 50% energy savings compared with other units

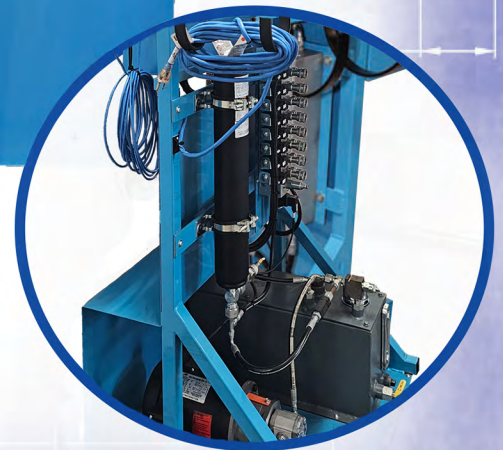

OSCO® *inc.*
RUNNERLESS MOLDING SYSTEMS

*"A quiet, versatile, low energy,
Valve Gate Sequencer for today's
Hi Tech Molding"*

VGS (Valve Gate Sequencer)

Available in Air or Hydraulic

This control is based on pump on demand technology. When the valve gates are fired, oil is used from the hydraulic accumulator. Once the pressure in the accumulator is below set point, the hydraulic pump replenishes the accumulator.

The pump then rests until oil is needed again. This design eliminates waste, oil heating, and dramatically reduces electricity use. The conventional systems use a motor running all the time, or an air over hydraulic pump. These systems are wasteful. The problem with the air over oil pumps is that it takes 8 electric horse power to produce one air horse power. Both of these conventional designs have no comparison to simple pump on demand technology.

The use of one single energy source (120 volts AC single phase) means it is literally like plugging in a hand tool. The pump on demand allows for no water source needed to cool the oil. These systems come standard with time based switching. Optional sequential switching or cavity pressure switching can be added.

Standard features:

- 120, 230, or 460 VAC available.
(120 VAC for up to 10 Zones max)
- Color 6-inch touch screen
- Timer based switching
- Caster cart for portability
- Quick disconnects for ease of set up
- On-Off display of each valve
- Energy savings accumulator design
- Super quiet operation
- Minimum press cycle time 10 seconds standard, faster cycle times consult factory

Options

- Part graphic import with gate location available
- Manifold design import with gate location
- Valve positioning verification with Inject inhibit
- Linear switching (sequential switching) with linear potentiometer
- Cavity pressure switching
- 230 VAC operation
- 460 VAC operation
- Air operation
- Older existing valve gate units can be upgraded with this controller



OSCO® *inc.*
RUNNERLESS MOLDING SYSTEMS

Call Us Direct
(800) 499-OSCO
★ www.oscosystems.com ★
2937 Waterview Drive
Rochester Hills, MI 48309

OSCO[®] *inc.*

RUNNERLESS MOLDING SYSTEMS

MICRO **VGS** Controller

PNEUMATIC VALVE GATE SEQUENCER

LOW COST!

HIGH VALUE!



Where Innovation Flows

Features:

- Up to 8 Zones of independent timing control.
- 25-foot quick disconnect cable.
- Portable
- 120 VAC

Optional:

- Switching block with LED gate open/close indicator
- Pneumatic sequencing manifold, mold or machine mountable

OSCO's

MICRO VGS Controller

PNEUMATIC VALVE GATE SEQUENCER



Valve wiring

10 conductor pig tail 25 foot cable with color coded wiring



Quick Disconnect



Trigger input

Quick-disconnect connector needs to be triggered with dry contacts from Inject signal or mold when closed.

Touch screen layout

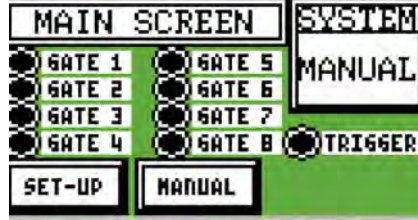

Main screen:

This screen shows the gates as they are turning on and off and the trigger input. Push button to switch between manual and auto operation and to screen change pushbuttons.



Set up screen:

This screen is where you adjust the delay and on time values for the gate. Pushing the next button will take you to the next gate.



Manual screen:

This screen allows each gate to be turned on for testing.

Optional



Switching Block with LED Zone Indicator



Pneumatic Sequencing Manifold

OSCO[®] inc.

RUNNERLESS MOLDING SYSTEMS

2937 Waterview Drive, Rochester Hills, MI 48309

Call Us Direct
(800) 499-OSCO

sales@oscossystems.com

★ www.oscossystems.com ★

Temperature Control Systems

Features:
**Full Compliment
of Systems**
Reliability
**Simplicity of
Operation**
Exceptional Value
Customer Service



OSCO[®]



All ITC's temperature control systems, associated components and accessories are ruggedly reliable, easy to use and maintain. Our simple down-to-earth design makes them highly adaptable in ever changing manufacturing environments. Affordability, adaptability, superior features and a 2-year limited warranty equates to a quick payback, improved molding cycles, less down time, reduced operating costs and an improved bottom line.



PORTABLE FLOOR STANDS

Part No	Use With
PFS-1	MF1, MF2 & MFHP-1
PFS-5	MF5 & MFHP-3
PFS-812	MF8, MF12 & MFHP-6

Manufactured of heavy gage steel tubing and provided with swivel & lockable casters. Stands are shipped un-assembled.

TRANSFORMER PACKAGES

Step-down 480v to 240v 3-phase

TP-6-5	6 kva with 5 zone stand
TP-9-8	9 kva with 8 zone stand
TP-15-8	15 kva with 8 zone stand
TP-15-12	15 kva with 12 zone stand
TP-30-8	30 kva with 8 zone stand
TP-30-12	30 kva with 12 zone stand
TP-45-12	45 kva with 12 zone stand

Pre-wired and assembled – includes Transformer, Welded stand with casters, Fused disconnect and 10 ft. AC input power cable (no connector on end).



MOLD CABLES

Power	(Amps)	Length	Thermocouple
PWC5-10	(15)	10 FT.	THC5-10
PWC5-20	(15)	20 FT.	THC5-20
PWC8-10	(15)	10 FT.	THC8-10
PWC8-20	(15)	20 FT.	THC8-20
PWC12-10	(15)	10 FT.	THC12-10
PWC12-20	(15)	20 FT.	THC12-20
PWCHP3-10	(30)	10 FT.	
PWCHP3-20	(30)	20 FT.	
PWCHP6-10	(30)	10 FT.	
PWCHP6-20	(30)	20 FT.	

Custom lengths and connector configurations are available upon request.

Mold Power Connectors have 6' leads with ground wire.



MOLD CONNECTORS

Power	(Amps)	Thermocouple
MPC-5	(15)	MTC-5
MPC-8	(15)	MTC-8
MPC-12	(15)	MTC-12
MPCHP-3	(30)	
MPCHP-6	(30)	

CONNECTOR KITS

Number	(Amps)	Description
MEK-5TC	(15)	Cable, Mold End Kit, 5 Zone, Thermocouple (Female)
MEK-8TC	(15)	Cable, Mold End Kit, 8 Zone, Thermocouple (Female)
MEK-12TC	(15)	Cable, Mold End Kit, 12 Zone, Thermocouple (Female)
MEK-PR	(15)	Cable, Mold End Kit, 5, 8 & 12 Zone, Power (Female)
FEK-PR	(15)	Cable, Frame End Kit, 5, 8 & 12 Zone, Power (Male)
FEK-TC	(15)	Cable, Frame End Kit, 5, 8 & 12 Zone, Thermocouple (Female)
FCK-PR	(15)	Main Frame, Connector, 5, 8 & 12 Zone, Power (Female)
FCK-TC	(15)	Main Frame, Connector, 5, 8 & 12 Zone, Thermocouple (Male)
MF-EC	All	Card Edge Connector Kit w/Contacts - All Main Frames
MF-ECC	All	Card Edge Connector - Contacts - All Main Frames
MF-CG	All	Card Guide, 6" - All Main Frames
ABC-15	All	Module Fuse - Special Fast Blow
MEKHP-3PR	(30)	Cable, Mold End Kit, 3 Zone, Power (Female) (High Power)
MEKHP-6PR	(30)	Cable, Mold End Kit, 6 Zone, Power (Female) (High Power)
FEKHP-3PR	(30)	Cable, Frame End Kit, 3 Zone, Power (Male) (High Power)
FEKHP-6PR	(30)	Cable, Frame End Kit, 6 Zone, Power (Male) (High Power)
FCKHP-3PR	(30)	Main Frame, Connector, 3 Zone, Power (Female) (High Power)
FCKHP-6PR	(30)	Main Frame, Connector, 6 Zone, Power (Female) (High Power)



MEK-12TC



FCK-PR



MEK-PR



FEK-PR



FCK-TC

1 & 2 ZONE CONNECTOR KITS (Combination Power & T/C)

Number	(Amps)	Description
1Z-ME	(15)	Cable End, Male Connector, 1 & 2 Zone
1Z-FE	(15)	Cable End, Female Connector, 1 & 2 Zone
1Z-MC	(15)	Mold Connector, Male, 1 & 2 Zone
1Z-FC	(15)	Frame Connector, Female, 1 & 2 Zone
1Z-MEL	(15)	Cable Coupler Hood, w/Latch, Male, 1 & 2 Zone
1Z-ME90	(15)	Cable End, Male Connector, 90°
1Z-IPP	(15)	Input Power Cord Plug, Female
MPTCHP-1	(30)	Mold Connector, 1 & 2 Zone (Male) (High Power)



1Z-FC



1Z-MC



1Z-ME



1Z-ME90



1Z-MEL



1Z-FE

1 & 2 ZONE CABLES (Combination Power & T/C)

	Number	(Amps)	Length
	PTC1-10	(15)	10 ft. long
	PTC1-20	(15)	20 ft. long
	PTCHP1-10	(30)	10 ft. long (High Power)
	PTCHP1-20	(30)	20 ft. long (High Power)

Custom Lengths and configurations are available upon request.

- Main Frames, Temperature Control Modules, Cables and other components are all sold separately.
- Please specify Voltage and Current requirements when ordering.
- ITC will gladly modify standard main frames, cables, etc., to accommodate your application.
- All modular components are "G" series compatible.

MAIN FRAME HARNESSES

Power	Zones	Thermocouple
MF-PH5	5	MF-TH5
MF-PH8	8	MF-TH8
MF-PH12	12	MF-TH12



MF-PH12



MF-TH12

MOLD WIRING JUNCTION BOX (EMPTY)



Part Number	Zones
MJB-5	5
MJB-8	8
MJB-12	12

Connectors must be ordered separately.

MOLD WIRING JUNCTION BOX (PRE-WIRED)



Part Number	Zones
MJBW-8	8
MJBW-12	12

Pre-wired with terminal strip & connectors.



MAIN FRAME BLANK PANEL

MFBP Fits all 15 & 30 amp main frames.

STANDARD ITC 15 AMP MAIN FRAME



MF1	1-Zone
MF2	2-Zone
MF5-150	5-Zone w/50 amp breaker
MF8-150	8-Zone w/50 amp breaker
MF12-150	12-Zone w/50 amp breaker
MF16-250	16-Zone w/(2) 50 amp breakers
MF16-170	16-Zone w/70 amp breaker
MF20-250	20-Zone w/(2) 50 amp breakers
MF20-170	20-Zone w/70 amp breaker
MF24-250	24-Zone w/(2) 50 amp breakers
MF24-170	24-Zone w/70 amp breaker
MF28-350	28-Zone w/(3) 50 amp breakers
MF32-350	32-Zone w/(3) 50 amp breakers
MF40-450	40-Zone w/(4) 50 amp breakers
MF44-450	44-Zone w/(4) 50 amp breakers
MF48-450	48-Zone w/(4) 50 amp breakers

STANDARD ITC 30 AMP (HIGH POWER) MAIN FRAME



MFHP-1-130	1-Zone w/30 amp breaker
MFHP-3-150	3-Zone w/50 amp breaker
MFHP-6-1100	6-Zone w/100 amp breaker

All ITC 15 & 30 amp Main Frame use our standard S20-D3C & UATC-20 control modules. Unless otherwise specified all main frames are 240v, 3-phase except MF1 & MF2 which are 240v single phase.

All components are neatly contained within the main frame. Special or Larger Control Systems are available upon request. Stacks of 2 or more main frames are rigidly fastened together into a single prewired unit.

VISIONS 3000 INTELLIGENT TEMPERATURE CONTROL SYSTEM

VCS-16-16-70	16 - Zone w/70 amp breaker	VCS-96-82-150	82 - Zone w/150 amp breaker
VCS-32-18-100	18 - Zone w/100 amp breaker	VCS-96-84-150	84 - Zone w/150 amp breaker
VCS-32-20-100	20 - Zone w/100 amp breaker	VCS-96-86-150	86 - Zone w/150 amp breaker
VCS-32-22-100	22 - Zone w/100 amp breaker	VCS-96-88-150	88 - Zone w/150 amp breaker
VCS-32-24-100	24 - Zone w/100 amp breaker	VCS-96-90-150	90 - Zone w/150 amp breaker
VCS-32-26-100	26 - Zone w/100 amp breaker	VCS-96-92-150	92 - Zone w/150 amp breaker
VCS-32-28-100	28 - Zone w/100 amp breaker	VCS-96-94-150	94 - Zone w/150 amp breaker
VCS-32-30-100	30 - Zone w/100 amp breaker	VCS-96-96-150	96 - Zone w/150 amp breaker
VCS-32-32-100	32 - Zone w/100 amp breaker	VCS-112-98-175	98 - Zone w/175 amp breaker
VCS-48-34-125	34 - Zone w/125 amp breaker	VCS-112-100-175	100 - Zone w/175 amp breaker
VCS-48-36-125	36 - Zone w/125 amp breaker	VCS-112-102-175	102 - Zone w/175 amp breaker
VCS-48-38-125	38 - Zone w/125 amp breaker	VCS-112-104-175	104 - Zone w/175 amp breaker
VCS-48-40-125	40 - Zone w/125 amp breaker	VCS-112-106-175	106 - Zone w/175 amp breaker
VCS-48-42-125	42 - Zone w/125 amp breaker	VCS-112-108-175	108 - Zone w/175 amp breaker
VCS-48-44-125	44 - Zone w/125 amp breaker	VCS-112-110-175	110 - Zone w/175 amp breaker
VCS-48-46-125	46 - Zone w/125 amp breaker	VCS-112-112-175	112 - Zone w/175 amp breaker
VCS-48-48-125	48 - Zone w/125 amp breaker	VCS-128-114-200	114 - Zone w/200 amp breaker
VCS-64-50-125	50 - Zone w/125 amp breaker	VCS-128-116-200	116 - Zone w/200 amp breaker
VCS-64-52-125	52 - Zone w/125 amp breaker	VCS-128-118-200	118 - Zone w/200 amp breaker
VCS-64-54-125	54 - Zone w/125 amp breaker	VCS-128-120-200	120 - Zone w/200 amp breaker
VCS-64-56-125	56 - Zone w/125 amp breaker	VCS-128-122-200	122 - Zone w/200 amp breaker
VCS-64-58-125	58 - Zone w/125 amp breaker	VCS-128-124-200	124 - Zone w/200 amp breaker
VCS-64-60-125	60 - Zone w/125 amp breaker	VCS-128-126-200	126 - Zone w/200 amp breaker
VCS-64-62-125	62 - Zone w/125 amp breaker	VCS-128-128-200	128 - Zone w/200 amp breaker
VCS-64-64-125	64 - Zone w/125 amp breaker		
VCS-80-66-150	66 - Zone w/150 amp breaker		
VCS-80-68-150	68 - Zone w/150 amp breaker		
VCS-80-70-150	70 - Zone w/150 amp breaker		
VCS-80-72-150	72 - Zone w/150 amp breaker		
VCS-80-74-150	74 - Zone w/150 amp breaker		
VCS-80-76-150	76 - Zone w/150 amp breaker		
VCS-80-78-150	78 - Zone w/150 amp breaker		
VCS-80-80-150	80 - Zone w/150 amp breaker		

Unless otherwise specified all VISIONS 3000 systems are 240v, 3-phase.

Systems are available for both 15 and 30 amp zones.

VISIONS 3000 offered with standard Key-pad Interface or Optional Touch-screen interface.

Valve Gate Sequencing Option.

Special or Larger Control Systems, as well as Dual or Low Voltage Systems are available upon request.



UATC-20 Temperature Control Module

Tomorrow's Temperature Control Module Today

The UATC-20 Temperature Control Module has been designed with the latest in microprocessor technology for Hot Runner Applications where state-of-the-art operational and diagnostic features are a requisite. There are many little features, such as gold-plated edge connector, incorporated within the UATC-20 which greatly enhances its operation. The UATC-20 is a rugged, simple to set-up and easy to use module which is versatile enough to move from project to project, with all the sophistication necessary for today's demanding molding requirements.

Some of the exceptional analytical functions found on the UATC-20 are:

- A diagnostic snapshot of the heaters operating characteristics are revealed when the current sensing feature is employed.
- Detects and alerts to the potentially dangerous condition of current leaking to ground.
- If power to the heater exceeds a selected value, the module will alarm and disables power to the heater preventing damage.
- Advance circuitry detects alarms and disables power to the heater in the event the triac fails in a shorted condition.
- In the event of a Thermocouple, Open or Shorted condition, the module will automatically go into APO (Average Power Output) mode, allowing operations to continue by providing the same average power to the heater as applied prior to the failure.
- Control algorithms are by means of our Adaptive-auto-tuning PID or FUZZY logic which makes intelligent control decisions and minimizes electrical stress on the heaters.
- Real time diagnostics fault detection & display.

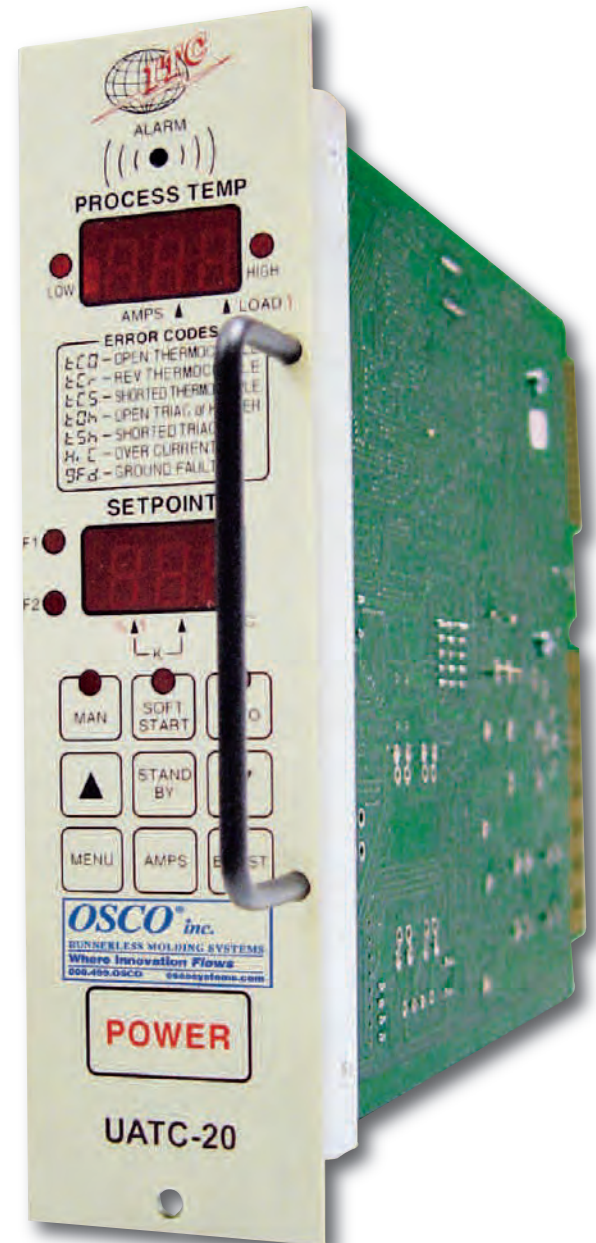

UATC-20 Temperature Control Module

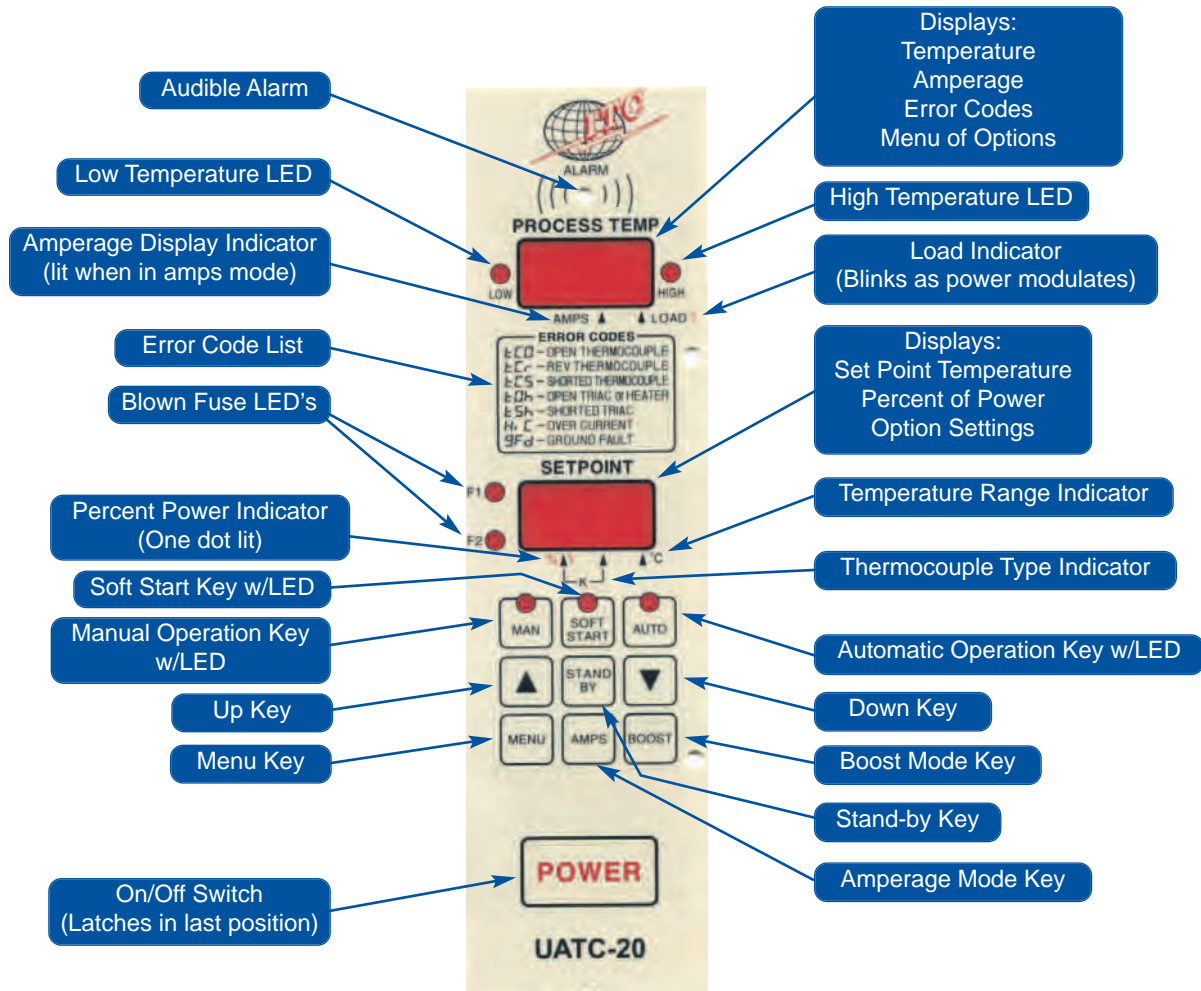

ENHANCED DIAGNOSTIC FEATURES:

- Ground fault detection (selectable range)
- High amperage alarm (selectable range)
- Thermocouple - open, shorted & reversed alarm
- Triac - shorted & open alarm
- Heater open alarm
- High and low temperature alarm
- Blown fuse indicators

SAFETY FEATURES

- High voltage thermocouple protection (fused)
- Module high current protection (fused)
- Power disabled to heater:
 - Triac shorted
 - Triac open
 - Heater open
 - Over temperature
 - High amperage
- Audible alarm (selectable on/off)

FEATURES:

- All functions & parameters are fully selectable from the "menu" feature on the keypad
- Amperage measurement & display
- Percent of power display (selectable range)
- Automatic or manual operation
- Automatic soft start
- Anti-arcing
- Boost (selectable temperature & time)
- Standby
- "F" or "C" temperature ranges
- Type "J" or "K" thermocouple
- Selectable control method – Adaptive-auto-tuning PID or Fuzzy Logic
- Panel lock out (selectable on/off)
- Electrically Isolated Front Panel
- APO (average power output) for T/C failure conditions
- Automatic test of LED segments
- Operating voltage 240V, 50/60 Hz or 120V
- Cold junction compensation
- Zero crossing triac
- This module operates both of our 15 and 30 main frames

MJBW Series Wired Mold Junction Boxes

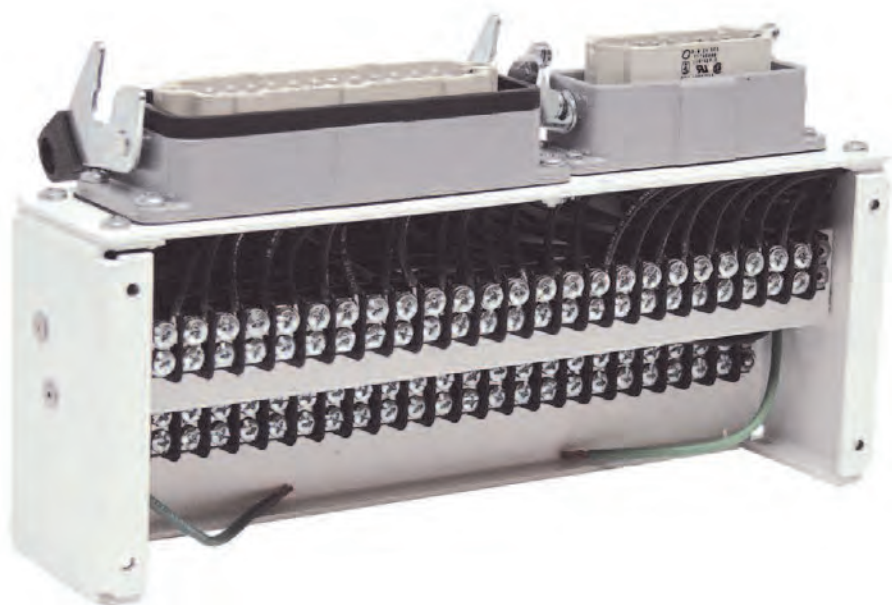

MJBW Series Mold Junction Box

		L	W	D
MJBW-5	5-Zone	8.66	2.34	4.00
MJBW-8	8-Zone	9.47	2.34	4.00
MJBW-12	12-Zone	10.53	2.34	4.00

Different configurations available upon request

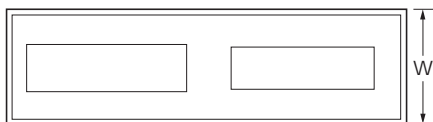
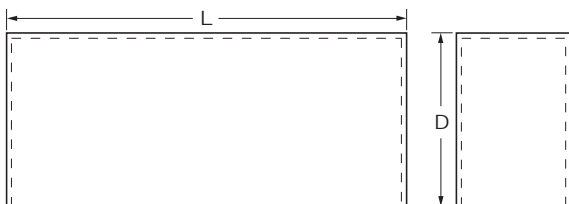

- Economical, easy to install and maintain
- 16 Amp 240 Volt
- Power and Thermocouple Connectors are Pre-wired to Terminal Strips
- Terminal Strips are Pre-numbered to correspond with Connectors
- Boxes are Powder Coated for Durability
- All Junction boxes are subjected to a rigorous testing program to ensure quality
- Junction Boxes Mount Directly on the mold

MJBW Series Wired Mold Junction Boxes

Mold Junction Boxes MJB Standard Series



- 16 Amp 240 Volt
- Most Economical Junction Box Available

MJB Series Mold Junction Box

		L	W	D
MJB-5	5-Zone	8.66	2.34	4.00
MJB-8	8-Zone	9.47	2.34	4.00
MJB-12	12-Zone	10.53	2.34	4.00

Different configurations available upon request



Mold Junction Boxes-High Power MJBHP Series



- High Power
(30 Amp 240 Volt)
Junction Boxes

MJBHP Series Mold Junction Box

		L	W	D
MJBHP-3	5-Zone	10.00	2.50	4.00
MJBHP-6	8-Zone	11.00	3.75	4.00

Different configurations available upon request

S20-DC3 Temperature Control Module

A superior Temperature Control Module designed for those applications where ease of operation, cost and features are of concern.

EXCEPTIONAL VALUE

EASE OF OPERATION

PREFERRED DIAGNOSTICS FEATURES

SUPERIOR OPERATING FEATURES

DURABILITY

WARRANTY

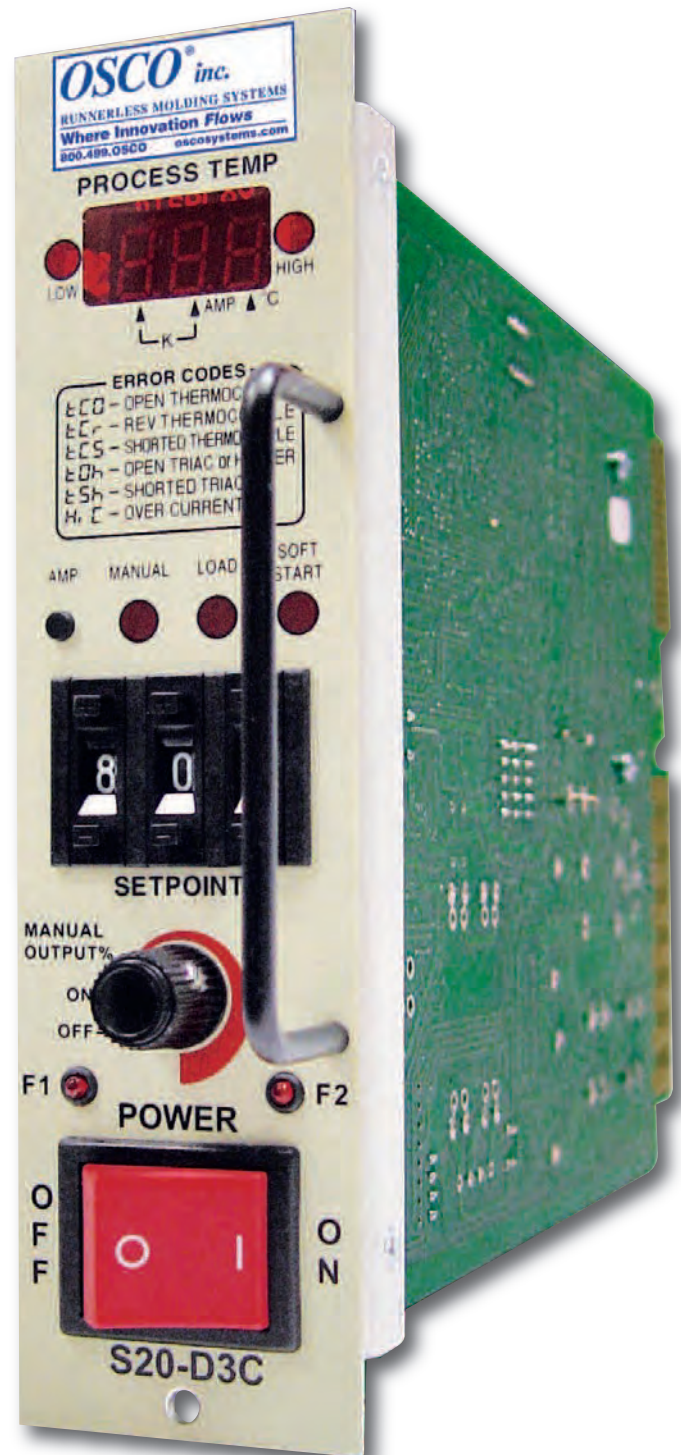

S20-DC3 Temperature Control Module

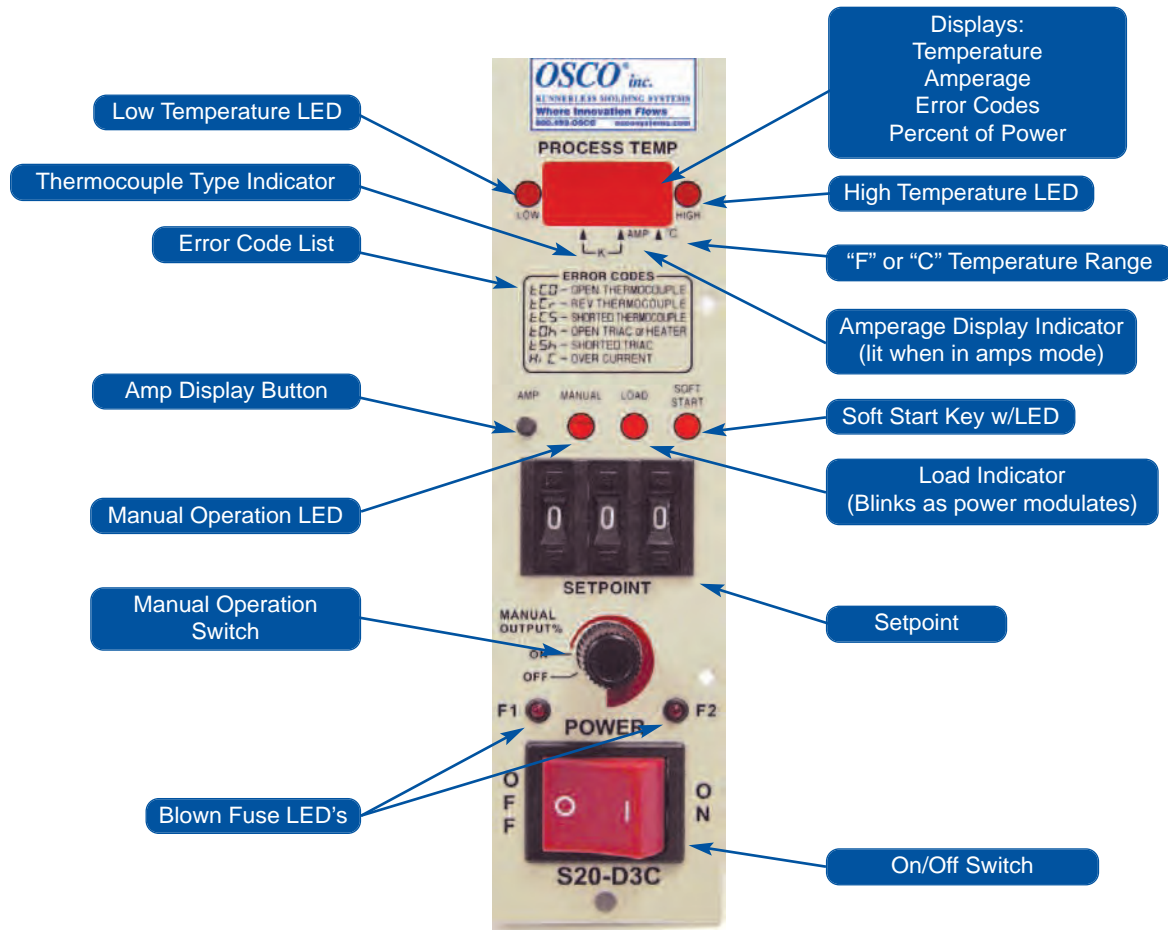

The S20-D3C Temperature Control Module has been intelligently designed, making it easy to set up and simple to use, while maximizing productivity, and providing an exceptional range of features, in order to meet the rigorous requirements of today's plastics industry. The Microprocessor based circuitry of the S20-D3C performs a full array of diagnostic and operational functions. Set-point temperatures are automatically maintained by means of our fully Adaptive-auto-tuning PID/FUZZY LOGIC function. The S20-D3C Module has been designed with the operator in mind; therefore it is easy to use. What could be simpler than, just turning it on, setting the operating temperature using the pinwheel set-point, then letting it run?

FEATURES:

- Automatic or Manual Operation
- Advanced Anti-Arcing Circuitry w/"ITC" Main frames
- Automatic Soft Start
- Amperage Measurement & Display
- Type "J" or "K" Thermocouple
- "F" or "C" Temperature ranges
- Selectable Control Methods – Adaptive-auto-tuning PID or Fuzzy Logic
- Manual Control for non-thermocouple applications
- Blown Fuse indicator
- This Module operates all "ITC" 15 and 30 amp main frames
- Compatible with "G" series main frames

DIAGNOSTICS:

The multifunction digital readout displays actual temperature, amps, percent of power, as well as various error codes:

- Open Thermocouple
- Reverse Thermocouple
- Shorted Thermocouple
- Open Triac or Heater
- Shorted Triac
- Over Current Condition

Individual LED's indicate:

- Manual Operation
- Soft Start
- High/Low Temperature – +/- 30° F
- Power output to the mold
- Blown Fuse
- "F" or "C" Temperature ranges
- "J" or "K" type thermocouple indicator
- Amp Measurement & Display

MFH-1 Single Zone Temperature Control System

Totally Digital & Self-Contained for Today's Industry

The MFH-1 is a 15 amp, microprocessor-based, single zone temperature controller designed for today's demanding needs. Its compact foot print, robust design with rugged extruded aluminum case and advanced features are ideally suited for use with hot sprue bushings, machine nozzles or in areas where this condensed size and all inclusive design are requisites.

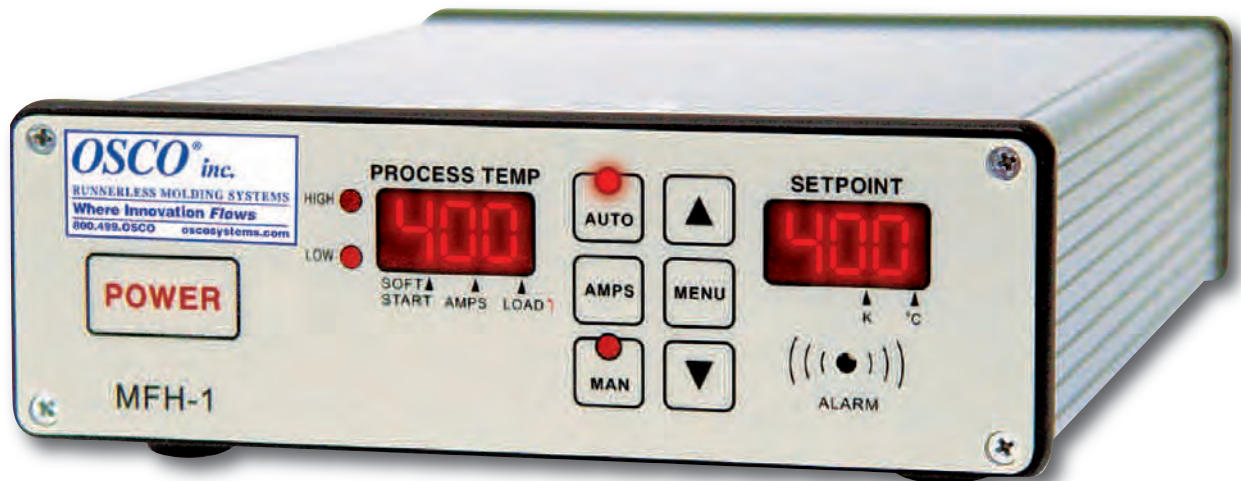

The latest in microprocessor technology offers many improved and unique operating features not found elsewhere, providing ease of use, the flexibility of menu selectable features and settings, as well as real time fault detection and alarm.

SUPERIOR FEATURES:

- Compact, durable and full featured design
- Easy to use
- Preferred diagnostic features
- Large Dual Digital Displays – Easy to read temperature, setpoint and diagnostic conditions
- Audible Alarm – Sounds during error conditions
- Fuses – Mounted on rear panel for easy access
- Soft Start LED Indicator – Lit when in soft start mode
- Heater Load LED Indicator – Lit as power is applied to heater
- Bumpless Transfer – APO (average power output) with learned % power for thermocouple failure conditions

SELECTABLE FEATURES:

- Auto or Manual Operation – LED mode indicator
- Type J or K Thermocouple – LED mode indicator
- F° or C° Temperature Range – LED mode indicator
- Amperage Monitoring & Display – LED indicates AMP mode
- Audible Alarm – Selectable on /off
- Front Panel Lockout – Selectable on/off

ENHANCED DIAGNOSTICS:

- High/Low Temperature – LED's indicate fault (selectable range)
- tCr Error Display – Thermocouple Reverse
- tCO Error Display – Thermocouple Open
- tCS Error Display – Thermocouple Shorted
- tOh Error Display – Triac/Heater Open
- tSh Error Display – Triac Shorted
- HiC Error Display – High Amperage Alarm (selectable range)

SAFETY FEATURES:

- High Voltage Thermocouple Protection (fused)
- Module High Current Protection (fused)
- Electrically Isolated Front Panel
- Power Disabled to Heater:
 - Triac Shorted
 - Triac Open
 - Heater Open
 - Over Temperature
 - High Amperage

MFH-1 Single Zone Temperature Control System

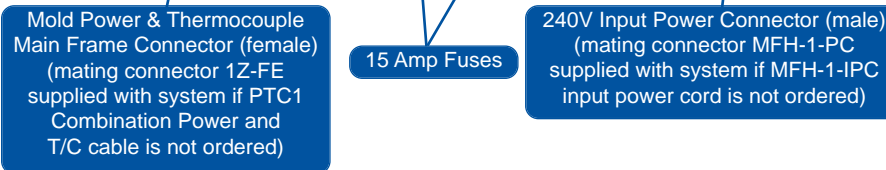
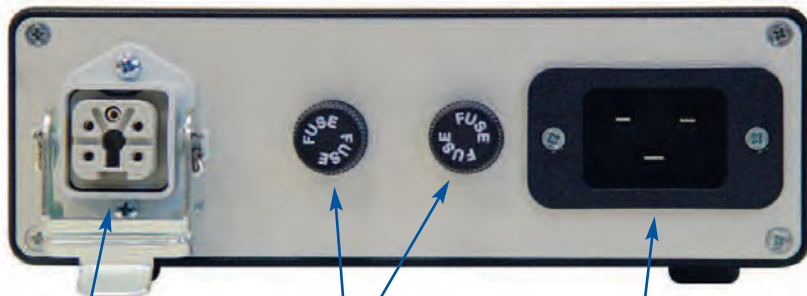
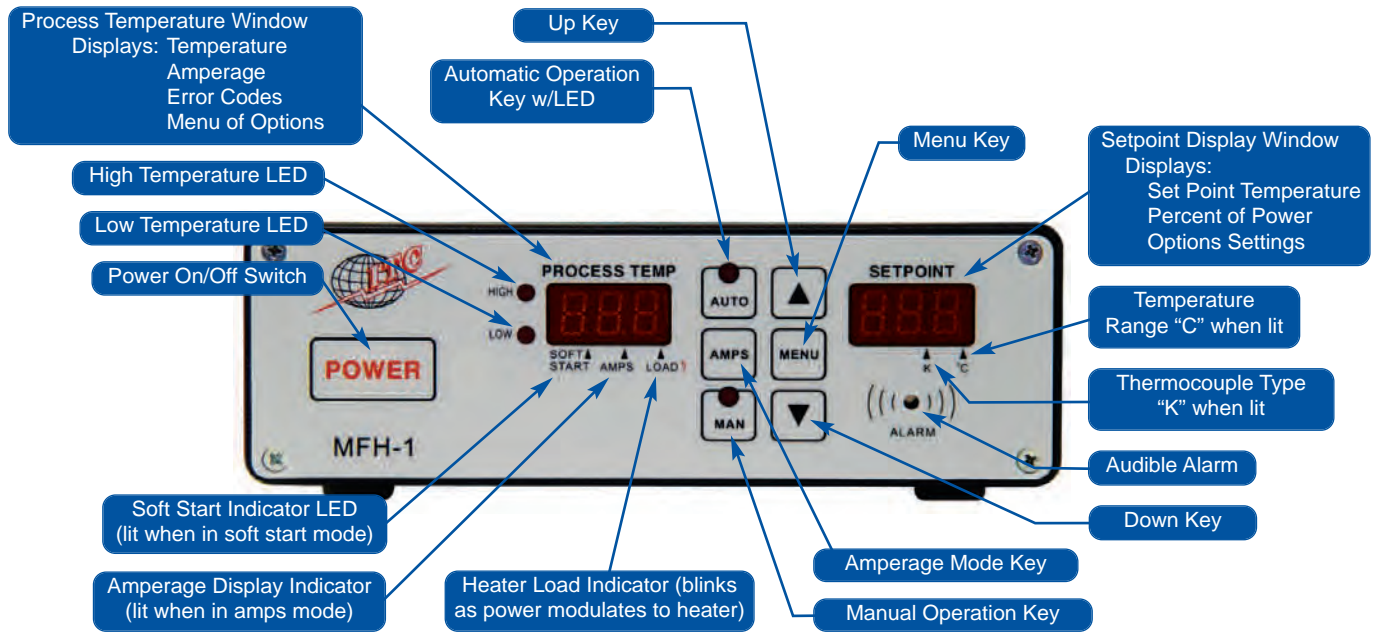

These connectors are supplied when **no cables are ordered**

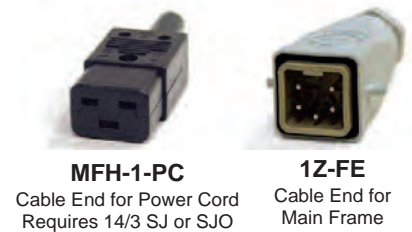

Optional Items



MFH-1-IPC
240Vac Input
Input Power Cable 240Vac



PTC1
Combination Power & T/C Cable

PRODUCT SPECIFICATIONS:

- 208 to 240Vac, single phase 120Vac (Optional)
- 50/60 Hz
- 15 Amp Capable
- 3600 Watts
- Size: 6 1/2" Wide, 2" High, 10" Deep
- Control System Power Usage, Less than 5 watts
- Set Point Range – 0° to 999° F
- Control Accuracy – +/- 1° F (0.5° C)
- Calibration Accuracy – Better than 0.2% full range
- Cold Junction Compensation
- Operating Temperature Range -32° to 120° F
- Output Drive – Internal solid state triac, zero crossing AC pulse

VISIONS 3000 CONTROL SYSTEM

A Serious Intelligent Hot Runner Temperature Control System



The **VISIONS 3000 CONTROL SYSTEM** is an advanced and affordable Hot Runner Temperature Controller designed for ease of use, reliability and precise temperature control. All **VISIONS CONTROL SYSTEMS** have the necessary flexibility to efficiently and economically operate in smaller single unit environments as well as centralized manufacturing facilities with sophisticated high cavitation processes. In today's demanding environment, molders require the capabilities of our ATC (Adaptive Thermal Control) self-tuning algorithm and powerful diagnostic (Power Temperature Comparator) features, which provides an invaluable insight into the operation of the mold.

AFFORDABILITY

EASE OF USE

DURABILITY

FEATURES

WARRANTY

SELF DIAGNOSTICS

COMMUNICATIONS

MULTI-LINGUAL



OSCO®

VISIONS 3000 CONTROL SYSTEM

The **VISIONS** series of temperature control systems set an Industry standard with its well proven robust design, precise temperature control, sophisticated features, ease of operation, dependability, modular design flexibility and scalability of size.

VISIONS 3000 software incorporates many exclusive and intuitive features which afford superior operation and control over a wide range of molding applications. The **VISION 3000** software also provides ease of access to a variety of informational and diagnostic functions, start-up functions, adjustable alarm limits, boost, standby, zone slaving, password protection, wiring diagnostics one-way and two-way communications, to mention just a few.

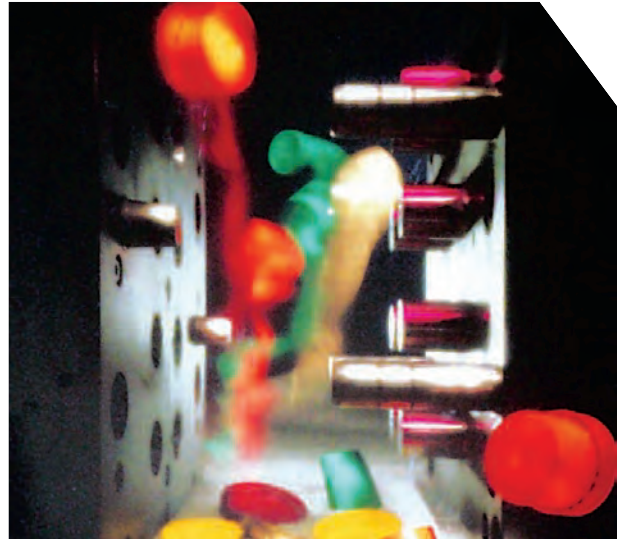

FEATURES AND HIGHLIGHTS

Affordability – What good are all the features in the world if the cost is prohibitive? **VISIONS** systems have the modularity to make them a reality for everyone.

ATC Control Technology – Adaptive Thermal Control technology provides an advanced algorithm which is adaptable to different molding environments for precise temperature control.

Boost – The boost function is user selectable from the controllers display or it can be automatic via peripheral interface.

Communications – **VISIONS 3000** powerful software provides sophisticated two-way communications capabilities. By means of Ethernet or Discrete protocol, remote devices can receive input from or give output commands to the **VISIONS 3000** controller. Remote devices can operate in either a supervisory function or as a command center. The **VISIONS 3000** also acts as a control device to start or cease operations.

Some of the commands which can be input to or output from the temperature controller are:

Output: Machine cycle, Toolguard, Tool temperature-safe to run, Tool diagnosis-safe to run, Alarm functions including Over/under temperature, Etc.

Input: Control start operation, Tool standby, Tool boost, Toolset data base selection, Temperature set points, Etc.

VISIONS 3000 CONTROL SYSTEM

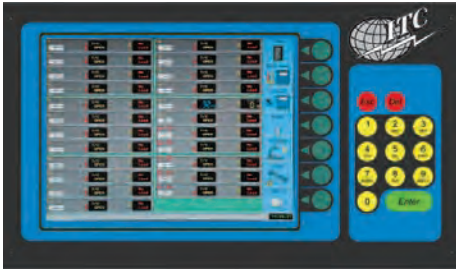

Ease of Use – VISIONS 3000 systems have been designed to be intuitive and simple to operate. Just turn the system on and enter the set points. The Intelligent Start-up function does the rest, taking the mold from warm-up to steady state in a manner which eliminates uneven thermal expansion. If during start-up, any zone fails to reach set point in a given time frame, the system will alarm indicating the deficient zone.

Graphics – VISIONS 3000 comes with a full set of functional graphics which offer the utmost in usefulness.

Large Color Screen – Graphics style LCD screen and ergonomic membrane arrangement is rugged and particularly well suited for clean room environments as well as the harsh realities of industrial life.



Multi-Lingual – English, Spanish, Danish, Deutsche, Italian, (Other languages can be easily incorporated).

Reliability – Rugged industrial hardened design & construction equates to a unit that will stand up to serious industrial environments.

Power Temperature Comparator – A diagnostic feature in which a graphic comparative view of actual power and temperature against time is displayed.

Safe Mode – Lowers the temperature of a zone or group of zones while the molding process is at idle for a short period of time. This function is either user selectable or automatic via peripheral interface.

Security – Three levels of security, plus the ability to define new passwords and access levels.

Self Diagnostics – An intuitive suite of functions which technicians love. These functions are always at hand from start up through operations.

Serviceability – The VISIONS 3000 is a truly modular system. Cards can be swapped in a matter of seconds with little or no interruption.

Slaving – When one or more zones do not have thermocouple feedback, they can be linked to zones with similar characteristics. This function can be selected at the controller or via peripheral interface.

Soft Start – An automatic feature within the Run function. It bakes moisture out of the tool by slowly bringing up the temperature of the mold to 200° F (93° C), then ramps up power until the measured value is within the proportional band for each zone.

System Alarm – The various alarm triggering events within the VISIONS 3000 SYSTEM, allow management to make intelligent operational decisions, such as allowing the system to continue operation, placing the tool in standby, or to shut down the tool. This allows management the ability to determine a strategy for the molding operation.

Tool Database – VISIONS 3000 intelligent control system is able to store and retrieve over 100 mold toolsets. The database can be activated by the user or via peripheral interface.

Toolguard – An exclusive patented feature of the VISIONS 3000 suite of software. Toolguard monitors the performance and operations on the mold and can automatically put the system into safe mode if it detects a failure in the cooling system, or if the tool has stopped cycling. Toolguard prevents excessive heat buildup in the mold, which can degrade material or even damage the mold.

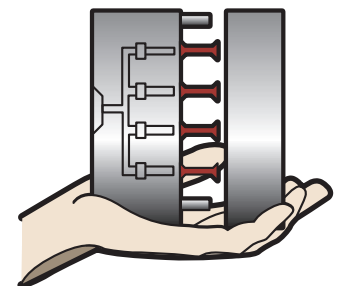
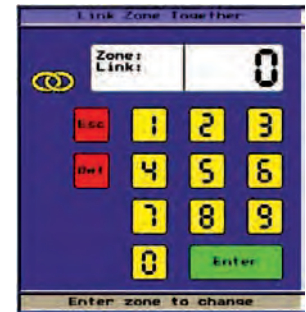

VISIONS 3000 CONTROL SYSTEM

Self Diagnostics

Self Diagnostics Capability:

The VISIONS 3000 Tool Diagnostics Suite performs a full set of functional tests to determine the condition of the mold, controller and machine operation.

Tool Diagnosis:

A function for troubleshooting new or existing tools, which checks for faults such as:

- Swapped heater or thermocouple wires. If one is found, the controller indicates the affected zone.
- Heater Power Monitoring (heater amperage and/or wattage) to detect leakage.
- Heater Resistance Monitoring to predict heater failure.
- Thermocouple Open, Short, Reversed, Etc.
- Measures resistance of each heater for failure analysis.



Toolguard:

This patented feature monitors the performance and operation of the mold cooling system. The controller will alarm putting the system into safe mode if a water cooling problem is detected.

Machine Interface:

VISIONS 3000 can take a cyclic or constant input from the machine and tool while in production and trigger a shut down if operations cease after a selectable period of time.

Visual Diagnostics:

LED's are visible through the front panel giving evidence of CPU communications, fuse condition and output activity for each zone.

Surface Graphs:

At a glance, Surface Graphs provide an immediate insight into the operation of all tool zones.

Trend Graphs:

Provides a scalable display of the historic values for a particular zone.

Graphic Visualization

Surface Graphs:

The Surface Graphs feature has been designed to offer an immediate insight into the operational characteristics of the tool. By using this patented feature, the operator no longer has to scroll each zone to determine tool operating conditions. Now anomalies can be seen with a single glance.

This feature displays temperature values, output power or output percentage information from the tool in a three dimensional graph. This diagnostics method provides a much quicker and simpler approach than tabulated data or trend graphs.

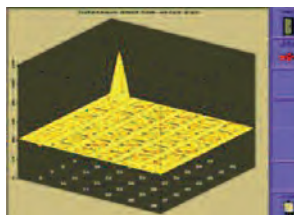

If anomalies are detected within a zone or group of zones, the particular Power Temperature Comparator Graph for those zones can be called up for an in-depth investigation.

Power Temperature Comparator Graphs:

A scalable display of the actual measured value of temperature & power against time for each zone on the mold. The Power Temperature Comparator Graph used in conjunction with the Surface Graph feature, allows for expeditious troubleshooting.

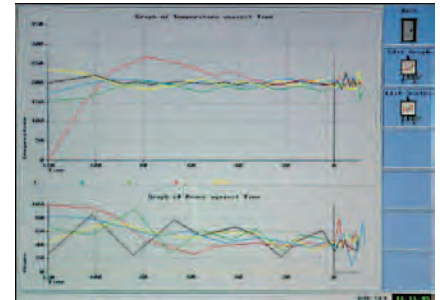

Viewing Modes:

Three viewing modes enable the operator to select the level of detail they wish to see (from 18 to 84 zones per screen).

Normal Display Mode:

Medium density. Displays up to 36 zones (Zone #, Set point, Temperature, Power & Errors).



Display Mode 1:

High density. Displays up to 84 zones at one time (displays the same information as in the normal display mode, except condensed).



Display Mode 2:

Low Density. Displays up to 18 zones (an expanded view of data for each zone, including a time line graph of measured temperature and output power).

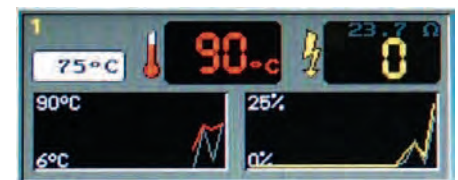

Options

- Low Voltage Hot Runner Control Systems
- Dual Voltage Hot Runner Control Systems
- High Amperage Zones
- Special / Custom Hot Runner Control Systems
- Special / Custom Cables & Connectors
- Valve Gate Sequencing Available